

**BassLink DC Quick Start Guide**

**BassLink DC Guide de démarrage rapide**

**BassLink DC Guía de inicio rápido**

**BassLink DC Guia de Início Rápido**

**BassLink DC Guida di avvio rapido**

**BassLink DC Kurzanleitung**

**BassLink DC Краткое руководство**

**BassLink DC Snabbguide**

**BassLink DC Pika-aloitusopas**

**BassLink DC Przewodnik szybkiego startu**

**BassLink DC Snelstartgids**

**BassLink DC Hurtigstartsguide**

**BassLink DC クイック スタート ガイド**

**BassLink DC 빠른 시작 가이드**

**BassLink DC 快速入门指南**

**BassLink DC 快速入門指南**

**BassLink DC Panduan Memulai Cepat**

**BassLink DC Hızlı başlangıç kılavuzu**

EN

FR

ES

PT

IT

DE

RU

SV

FI

PL

NL

DA

JP

KO

CHS

CHT

ID

TR

Торговая марка : Infinity

Назначение товара : Автомобильная акустическая система

Изготовитель : Харман Интернешнл Индастриз Инкорпорейтед, США, 06901 Коннектикут, г.Стэмфорд, Атлантик Стрит 400, офис 1500

Страна происхождения : Китай

Импортер в Россию : ООО "ХАРМАН РУС СиАйЭс", Россия, 127018, г.Москва, ул. Двинцев, д.12, к 1

Гарантийный период : 1 год

Информация о сервисных центрах : [www.harman.com/ru](http://www.harman.com/ru) тел. +7-800-700-0467

Срок службы : 5 лет

Номер документа соответствия : Товар сертифицирован 

Дата производства : Дата изготовления устройства определяется по двум буквенным обозначениям из второй группы символов серийного номера изделия, следующих после разделительного знака «-». Кодировка соответствует порядку букв латинского алфавита, начиная с января 2010 года: 000000-MY0000000, где «М» - месяц производства (А - январь, В - февраль, С - март и т.д.) и «Y» - год производства (А - 2010, В - 2011, С - 2012 и т.д.).

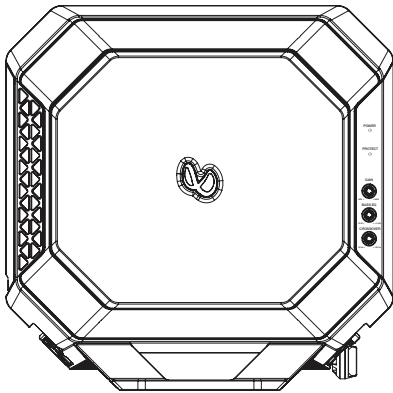

Thank you for choosing the Infinity BassLink DC. To ensure maximum performance, we strongly recommend that you have it installed by a qualified professional – while these instructions offer general installation guidance, they do not show specific installation methods for your particular vehicle. If you do not have the necessary tools or hands-on experience, do not attempt the installation yourself; instead, ask your authorized Infinity car-audio dealer about professional installation options. Please refer to your owner's manual (available at [infinityspeakers.com](http://www.infinityspeakers.com)) for more detailed instructions. (<http://www.infinityspeakers.com>)

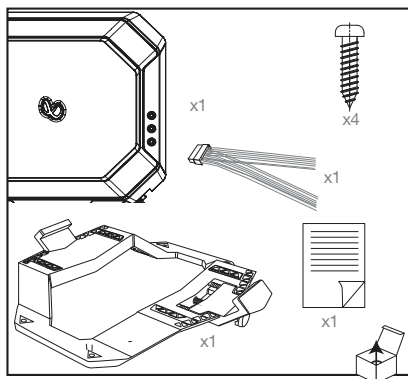

## INSTALLATION

**IMPORTANT:** Disconnect the vehicle's negative (-) battery terminal before beginning the installation.

- Always wear protective eyewear when using tools.
- Check clearances on both sides of a planned mounting surface. Be sure that screws or wires will not puncture brake lines, fuel lines, or wiring harnesses, and that wire routing will not interfere with the safe vehicle operation.
- When making electrical connections, make sure they are secure and properly insulated.
- If you must replace the fuse, be sure to use the same type of fuse and current rating as that of the original.
- Drill pilot holes in the mounting surface.
- Attach the BassLink DC to the mounting surface with four appropriate mounting screws.

**NOTE:** You may find it more convenient to make all of the connections to the amplifier before you permanently mount it

### Choosing a Mounting Location

Choose a location that doesn't prevent you from loading or unloading cargo, interfere with fold-down seats, or keep you from being able to open or close the trunk lid, or interfere with the safe operation of the vehicle.

## Mounting the BassLink DC

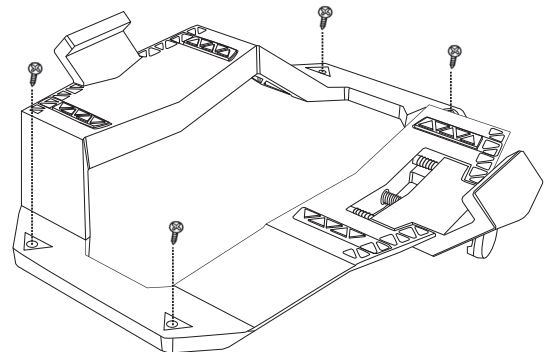

Choose a location that doesn't prevent you from loading or unloading cargo, and doesn't interfere with normal vehicle operation. Then, secure the mounting bracket using four sheet metal screws in the slots at each of its four corners. It may be more convenient to mount the bracket without the BassLink in place, once you have test-fitted the assembly.

To attach the bracket to the BassLink DC, slide the rear arm of the bracket into the bottom rear slot of the BassLink DC, and allow the BassLink DC to rest on the bracket. To secure the spring-loaded front arm of the bracket, turn the knob clockwise until the front arm slides into the front slot of the BassLink DC.

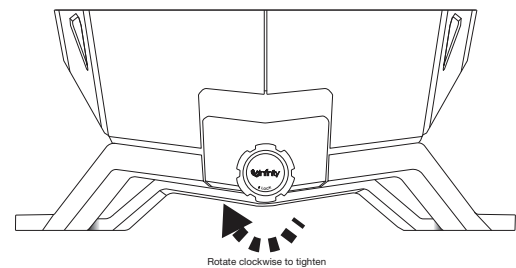

## BassLink DC wiring harness

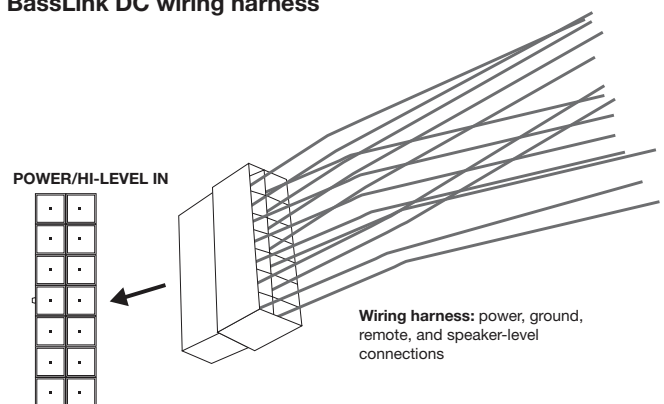

**NOTE:** to access the power and signal inputs on the BassLink DC, simply remove the cover on the side panel by pulling. Once all connections are made, replace the cover.

The included wiring harness features power, ground, remote signal, and speaker-level input wires.

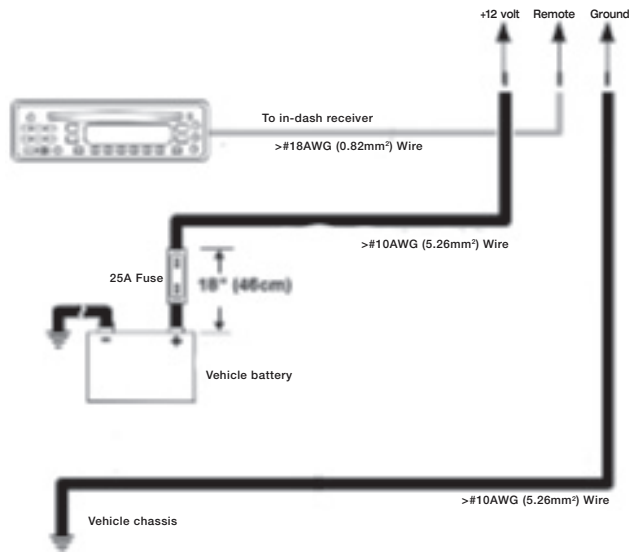

**For power:** Connect the 2 yellow power wires from the BassLink DC harness to the vehicle's + (positive) battery terminal. You must also install a fuse holder with a 25A fuse within 18" of the battery.

**For ground:** Connect the 2 black ground wires from the BassLink DC harness directly to a solid point on the vehicle's chassis. Use sandpaper to clear the paint from the metal surface at the chassis location. Use a star-type lock washer to secure the wire.

**Remote:** Connect the blue/white remote wire from the BassLink DC harness to the remote output wire on your head unit, if it has one, and you're using the line-level inputs.

**If you have a head unit with speaker-level outputs only:** Use speaker wire to connect the four speaker-level outputs from the head unit to the four high-level input wires on the BassLink DC's harness. If you have a head unit with only two speaker-level outputs, you can connect the two outputs to either the front or rear high-level input wires.

**Speaker wire color codes on the BassLink DC wiring harness (the colors of your vehicle's speaker wires will vary; consult your owner's manual, or contact a professional for help identifying them):**

<b>Green</b>	<b>Left rear +</b>
<b>Green/black</b>	Left rear -
<b>White</b>	Left front +
<b>White/black</b>	Left front -
<b>Purple</b>	Right rear +
<b>Purple/black</b>	Right rear -
<b>Gray</b>	Right front +
<b>Gray/black</b>	Right front -

**Plugging in the BassLink DC wiring harness:** When you've made all the necessary power and signal connections to the BassLink DC wiring harness, plug the harness into the input marked "POWER/HIGH-LEVEL IN".

## Line-level Signal Inputs

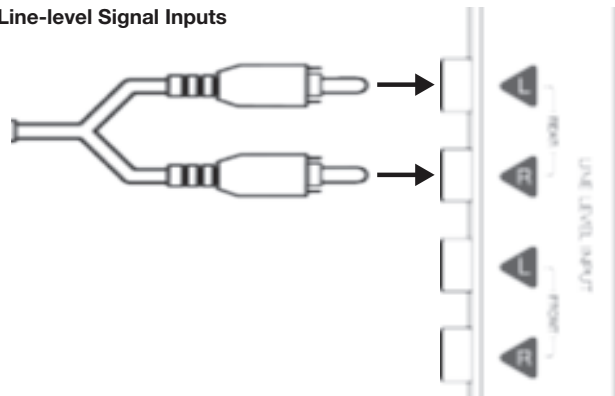

**If you have a head unit with a dedicated subwoofer output (line-level):** Connect the subwoofer output from the head unit to either the front or rear line-level inputs using an RCA patch cable (sold separately).

**If you have a head unit with four line-level outputs:** You can use RCA patch cables to connect all four line-level outputs to the four line-level inputs on BassLink DC.

**If you have a head unit with only two line-level outputs:** You can connect the two outputs to either the front or rear line-level inputs.

## INPUT LEVEL SWITCH

If using an aftermarket radio's RCA-level output, set the Input Level switch to the "LO" position. If using high-level outputs, start the control-setting process with the Input Level switch set in the "HI" or "HI2" position.

## AUTO TURN ON Switch

If you did not connect the BassLink DC's remote turn-on connection, set the Auto Turn On switch to "On". If you did connect the BassLink DC's remote turn-on connection, set the Auto Turn On switch to "Off".

## 1. Setting the Gain

Adjusting the gain lets you match the input sensitivity of BassLink DC with the output of your receiver, and match the relative volume to the rest of the speakers in your vehicle.

1. Start with gain control set to minimum, and the crossover control and bass control rotated midway.
2. Choose music with substantial bass content and turn the volume control on your receiver to  $\frac{3}{4}$  of its total output.
3. Adjust the gain control clockwise, listening carefully to the bass output. If you hear distortion, turn the gain control counterclockwise to decrease the gain.
4. Switch the phase back and forth to determine which setting provides the most clean bass output.
5. Adjust the crossover control until the BassLink DC plays only low-frequency information – you should not hear elements such as vocals coming from the woofer.
6. Adjust the bass-boost control clockwise or counterclockwise to suit your taste.

## SPECIFICATIONS

Driver Complement	: 10"(250mm) Woofer and 10"(250mm) Passive Radiator.
Amplifier Power	: 200W RMS
Frequency Response	: 20Hz – 120Hz
Fuse	: 25A
Maximum Current Draw	: 22.6A
Quiescent Current Draw	: <450mA
Input Sensitivity	: 0.05 V – 2.0 V Low-Level Input; 0.5 V – 20V High-Level Input
Crossover Frequency	: 50Hz – 120Hz
Crossover Slope	: 12dB/octave
Bass Boost	: 0dB to +9dB @ 55Hz
Dimensions (L x W x H)	: 14-1/2" x 11-1/4" x 14-3/8" (367.5mm x 284.8mm x 364.9mm)



HARMAN International  
Industries, Incorporated  
8500 Balboa Boulevard,  
Northridge, CA 91329 USA  
www.infinityspeakers.com

© 2016 HARMAN International Industries, Incorporated. All rights reserved.

Infinity is a trademark of HARMAN International Industries, Incorporated, registered in the United States and/or other countries. Features, specifications and appearance are subject to change without notice.



# INFINITY BASSLINK DC

Compact powered subwoofer system



## New Infinity subwoofer gets amazing performance from a small package.

Infinity integrated subwoofer system with 10" driver and 10" passive radiator delivers big bass with 200W RMS amp and high-tech compact enclosure. Subwoofer upgrade is now possible in applications where custom boxes would not normally fit. Quick-disconnects and quick-release connections enable easy hook-up. Given size, shape and sound, the BassLink DC can maximize bass response for virtually any vehicle.

### Features

- ▶ Flexible Placement
- ▶ High Technology Glass-Reinforced ABS Enclosure
- ▶ Easy Hook-up and Placement
- ▶ Efficient 200-watt Class D amplifier
- ▶ High- and Low-Level Inputs
- ▶ Subwoofer User Controls
- ▶ Audio Sense Circuit
- ▶ Audio Detect
- ▶ 0.75 cu. ft.



# INFINITY BASSLINK DC

Compact powered subwoofer system



## Flexible Placement

Integrated system with extremely compact footprint allows subwoofer upgrade where other custom enclosures would not normally fit and achieves remarkably impressive bass output.

## High Technology Glass-Reinforced ABS Enclosure

ABS enclosure is water-resistant and suitable for marine and off-road applications without the buzz and resonance problems generally associated with traditional wood boxes.

## Easy Hook-up and Placement

Quick disconnects and quick-release connections are provided for easy hook-up and system placement options—including complete removal when extra cargo space is needed.

## Efficient 200-watt Class D amplifier

BassLink DC is powered with an extremely efficient 200-watt RMS Class D amplifier that radiates very little heat and requires minimal current from the car's electrical system. The amplifier also includes a precision limiter/compressor to control system behavior at peak power levels.

## High- and Low-Level Inputs

The BassLink DC system is designed to be compatible with nearly every type of car audio system. It has speaker-level inputs for factory OEM systems or RCA line-level inputs for high-end aftermarket systems. BassLink DC also has four channel high level inputs to ensure non-fading bass.

## Subwoofer User Controls

BassLink DC is outfitted with a complete set of user controls. There is a 180 degree phase switch, an input sensitivity switch to optimize the audio inputs, Variable Bass EQ (with up to 9dB of boost at 70Hz), and a crossover frequency control.

## Audio Sense Circuit

An automatic audio sense circuit turns the amplifier on whenever it detects an audio signal. There is a switch to enable or disable audio sense (when disabled, subwoofer can be enabled by the remote-in terminal).

## Audio Detect

The BassLink DC has an audio detect circuit that allows the subwoofer to turn on and timeout to standby. Timeout is fixed at 10 minutes. (The system has a relatively slow time constant to avoid unintentional turn-on.)

## 0.75 cu. ft.

The BassLink delivers higher output and deeper bass from an integrated system that is far more compact than conventional woofer enclosure systems. Less than one cubic foot and you're better than the rest.

## What's in the Box:

BassLink DC  
QSG

## Product specifications:

- ▶ Integrated Powered Subwoofer System
- ▶ Driver Complement: 10" (250mm) Woofer and 10" (250mm) Passive Radiator
- ▶ Amplifier Power: 200 RMS
- ▶ Frequency Response: 20Hz – 120Hz
- ▶ Fuse: 25A
- ▶ Maximum Current Draw: 22.6A
- ▶ Quiescent Current Draw: <450mA
- ▶ Input Sensitivity: 0.05V – 2.0V Low-Level Input; 0.5V – 20V High-Level Input
- ▶ Crossover Frequency: 50Hz – 120Hz
- ▶ Crossover Slope: 12dB/octave
- ▶ Bass Boost: 0dB to + 9dB @ 55Hz
- ▶ Dimensions (L x W x H): 14-1/2" x 11-1/4" x 14-3/8" (367.5mm x 284.8mm x 364.9mm)



HARMAN International Industries, Incorporated  
8500 Balboa Boulevard, Northridge, CA 91329 USA  
www.infinityspeakers.com

© 2016 HARMAN International Industries, Incorporated. All rights reserved. Infinity is a trademark of HARMAN International Industries, Incorporated, registered in the United States and/or other countries. Features, specifications and appearance are subject to change without notice.